

Centrifugal Separator for Milk and Whey



THE PRODUCT MAXCREAM 20T is a centrifugal separator configured as a concentrator for dairy application, with double paring discs, partial and total automatic discharge capabilities, and ready for Clean-In-Place (CIP). MAXCREAM 20T is delivered as a skid, mounted on a platform and cabled with its own cabinet.

THE APPLICATION MAXCREAM 20T has been designed by HAUS for the dairy industry, specifically for milk or whey separation. Its purpose is to separate the fatty components from milk or whey, concurrently removing contaminating solids. MAXCREAM 20T produces:

- Milk or whey with reduced fat content (standardization) and free from solids
- Cream, with desired fat concentration (skimming, concentration)
- Sludge, composed of solid contaminants and as low as possible milk.

MAXCREAM 20T is also effective in somatic cell and spore reduction.

SPECIAL FEATURES MAXCREAM 20T belongs to a new generation of separators, designed exclusively for dairy application. Highest level of efficiency is achieved, whilst the product is treated gently, preserving high hygiene. Thanks to advanced features like:

- High Rotational Speed: generating a huge centrifugal force, thanks to quality material and mechanics.
- Disc Stack: closely spaced discs of large diameter, creating a large surface of separation
- Submerged Feed Pipe: a system to introduce and accelerate the product gently, minimizing shear stress, oxygen pick-up and foaming
- Double Valve Discharge System: able to perform very fast and precise discharges, reducing the loss of milk and valuable components (fat, protein)
- Double Paring Disc Outlets with Counter-Pressure Valves: to regulate the separation and obtaining the required concentration of cream.
- Strict Hygienic Configuration: quality material, polished discs, fine treatment of contact surfaces to avoid product deposits, and an optional CIP system
- Easy Drive: VFD for smooth start and stops without friction clutch and with lowest possible energy consumption, PLC for automatic control of centrifuge separation and CIP sequence, HMI to adjust operational parameters and to monitor alarms.
- High Stability Basement, made in heavy cast iron covered with stainless steel cladding
- Skid Assembly, easy to put in place, ready to operate

APPLICATIONS

- hot milk separation
- whey separation
- milk and whey skimming
- milk standardization
- cream concentration
- buttermilk separation

HIGHLIGHTS

- separation efficiency
- skimming efficiency
- cream concentration
- gentle treatment
- removal of solid
- efficient discharging
- hygienic design
- quality material
- CIP ready
- parameter setting
- energy saving

OPERATING PRINCIPLES

The product mixture is introduced into the bowl, where it is put into rotation. The centrifugal force results in the product mixture being separated according to density differences. The milk is forced to flow through tiny spaced discs, which allows the skimmed milk and the cream to flow in opposite directions.

The skimmed milk overflows from the periphery through the heavy phase paring disc (centripetal pump), to exit under pressure. The lighter liquid flows in the center through the light phase paring disc, also exiting under pressure. The counter-pressure valves on the outlet pipes can be adjusted to regulate the liquid distribution inside the bowl.

Heavier solid particles accumulate in the in the sludge volume of bowl periphery, from where they are discharged periodically. During partial discharge operation, only the sludge volume is emptied. Differently, the total discharge operation empties the entire bowl volume. Any sequence of partial and total discharge can be programmed into the PLC via the HMI interface, such that it is carried over by the automatic control system.

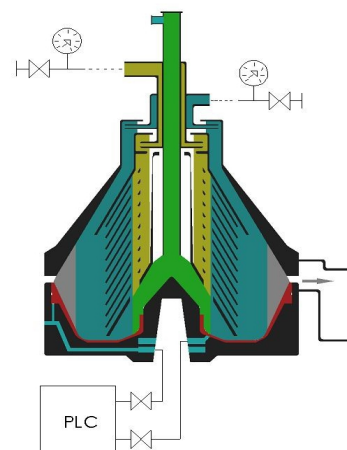

STANDART CONFIGURATION

- separator assembled on skid
- control panel with PLC and HMI
- operating water booster pump
- electrical motor with VFD
- set of special tools and parts for commissioning
- operator manuals

OPTIONALS

- flow control accessories
- product feed pump and feed valve
- CIP (Cleaning In Place) system
- standardization unit

TECHNICAL DATA

Capacity, skimming*	up to 20.000 L/h
Capacity, standardization**	up to 25.000 L/h
Bowl/ Sludge Volume	18,5 / 6 L
Installed Motor Power	30 kW
Separator weight (total, empty)	1400 kg
Bowl weight (alone, empty)	400 kg
Skid overall weight	1600 kg
Noise level	85 dB(A)
Dimension (LxW, H)	1730x2400, 2090

* Corresponding to skimming hot milk with <0,05% residual fat

** Corresponding to standardization of hot milk

MAIN MATERIALS

Bowl Body	EN1.4418
Bowl Hood and Sliding Piston	Duplex EN1.4462
Discs	AISI 316 EN1.4401
Other Contact Surfaces	AISI 304 EN1.4301
Cover, Sludge Collector	AISI 304 EN1.4301
Separator Frame	Cast Iron with Stainless Steel cladding
Control Panel	AISI 304 EN1.4301
Skid Platform	AISI 304 EN1.4301

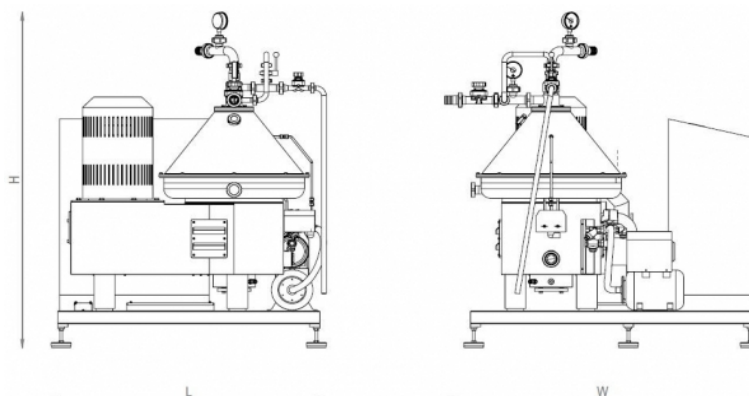

CUSTOMER SATISFACTION



USER FRIENDLY



RELIABLE & QUALIFIED SERVICE



24/7-365 DAYS CONTINUOUS SERVICE



ORIGINAL SPARE PARTS